

**20****INSTALACIÓN DE LAS PUERTAS**  
DOOR INSTALLATION**AJUSTE DE ALTURA**  
/ HEIGHT  
ADJUSTMENT**AJUSTE DE PROFUNDIDAD**  
/ DEPTH ADJUSTMENT**AJUSTE LATERAL**  
/ LATERAL  
ADJUSTMENT

Al finalizar el ajuste, cubra las cajas con las tapas adhesivas / After tightening all the panels, cover the minifix cams with the adhesive caps.

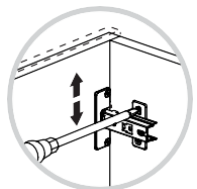
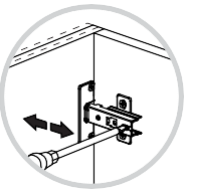
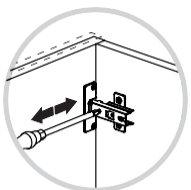
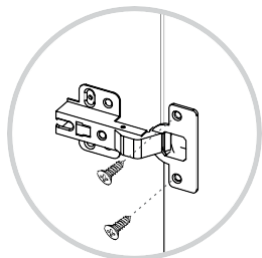
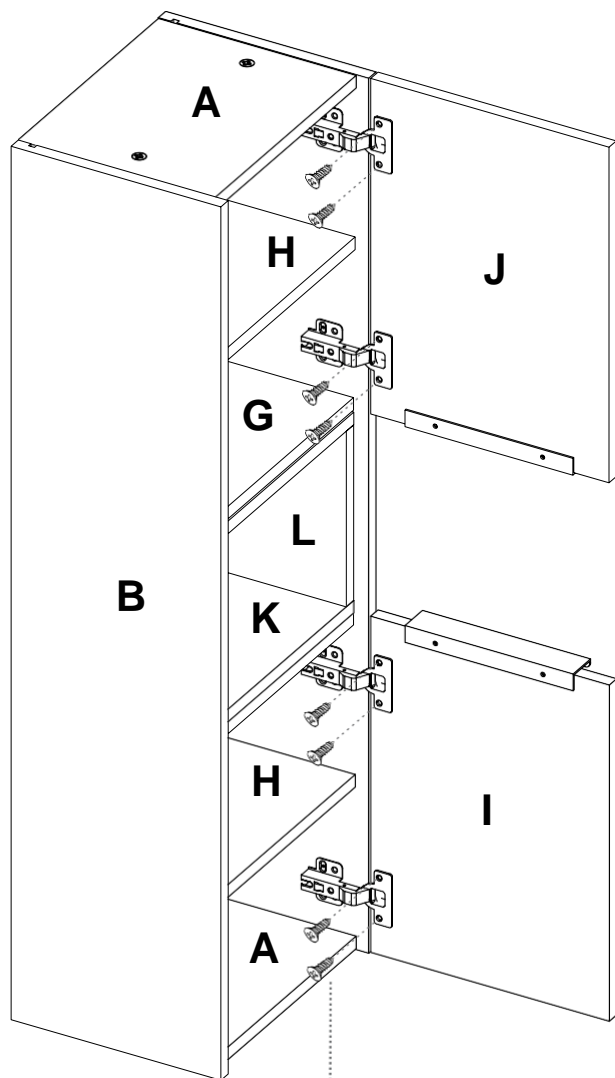
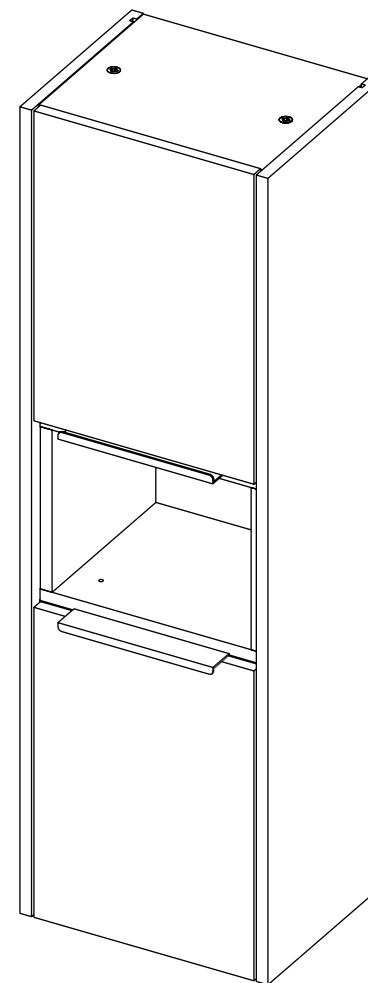

Al terminar de armar, despegue los adhesivos (en caso de que queden residuos de pegamento, limpie la superficie con alcohol) / After finishing the assembly, take off the adhesives. (In case of glue residues, wipe them with alcohol)

**RTA**  
muebles**INSTRUCCIONES DE ENSAMBLE**  
ASSEMBLY INSTRUCTIONS

Alto/ Height: 104,1cm / 40,98 in  
Ancho/ Width: 32 cm / 12,59 in  
Fondo/ Depth: 25 cm / 9,84 in

**LOTE No:** \_\_\_\_\_By: **RTA**  
muebles

**MUEBLE AUXILIAR DE BAÑO**  
**KIOTO**  
/Kioto  
*Auxiliary Bathroom Cabinet*

## RECOMENDACIONES IMPORTANTES

### KEY RECOMMENDATIONS

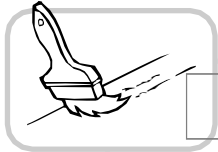

NO pinte el mueble /  
Do not paint the  
furniture.



NO mojar o ubicar  
a la intemperie /  
Do not expose to rain  
or direct sun.

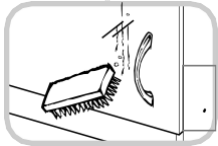
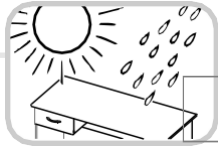

NO lavar las manijas o  
tiraderas con jabones o  
elementos abrasivos /  
Do not wash handles or  
dumps with soap or  
abrasives.

NO sobrecargue el mueble.  
no exceda el peso de 30 kilos  
para gabinetes de cocina /  
Do not overload the cabinet.  
Weight max. 66lbs  
for kitchen cabinets.

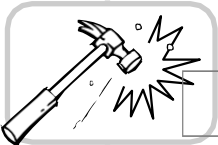

NO golpear ni martillar  
el mueble (hágalo sólo  
donde se indique) /  
Do not hit or hammer  
the furniture (just do it  
where is indicated).

NO permita que los niños  
manipulen el mueble, puede  
voltearse y lastimarlos /  
Do not allow children to  
handle the cabinets or  
drawers, they could get hurt.

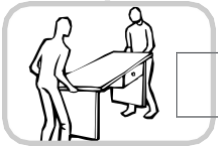

SIEMPRE levante el  
mueble entre dos  
personas, NO lo arrastre /  
Do not drag the furniture.  
Lift it between two people.

Limpie con paño seco,  
/ Clean with a dry cloth.



## HERRAJES BÁSICOS PARA MUEBLES RTA BASIC HARDWARE FOR RTA FURNITURE

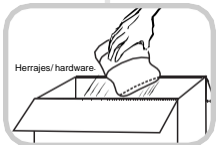

1. Abrir la caja del mueble  
y buscar la bolsa con los  
herrajes / Open the box  
and look for the hardware  
bag.

3. Separe los herrajes para  
facilitar su identificación  
durante el armado /  
Separate hardware for easy  
identification during  
assembly.

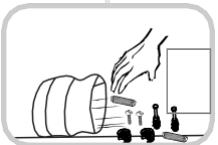
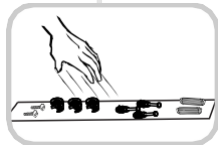

2. Abrir el paquete y  
comprobar que el  
contenido de las piezas es  
correcto / Open the  
package and verify that  
the content of the pieces  
is correct.

4. Arme el mueble en un lugar  
limpio y en una superficie  
plana / RTA furniture  
must be assembled  
in a clean place and on  
a flat surface.

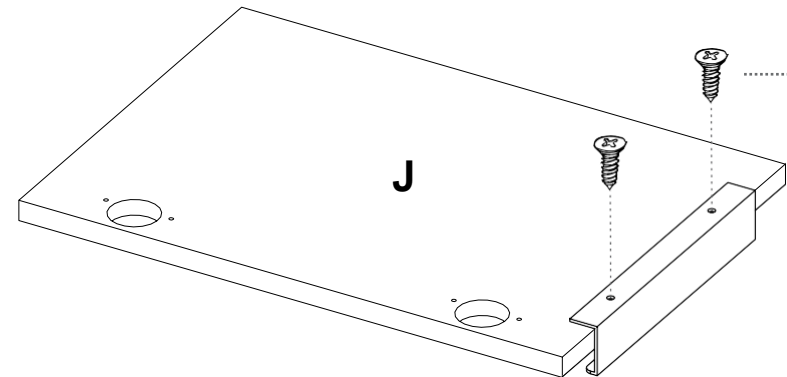
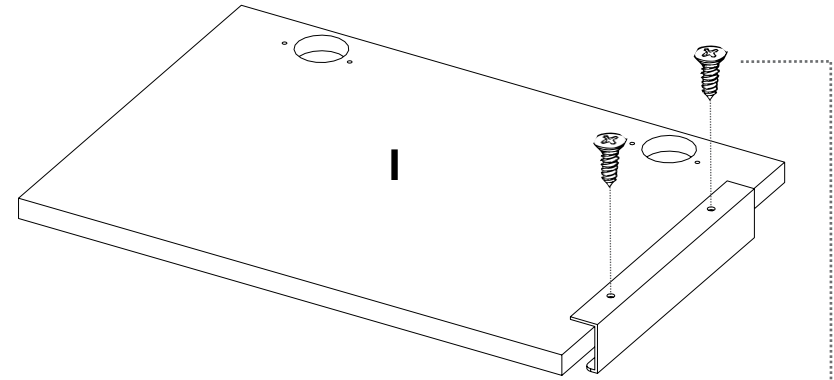
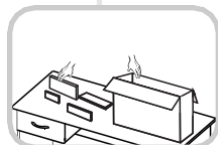

## INSTALACIÓN A LA PARED FIXING THE CABINET TO THE WALL

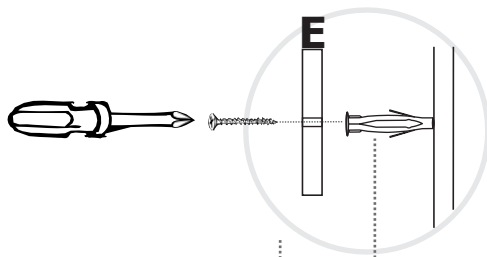
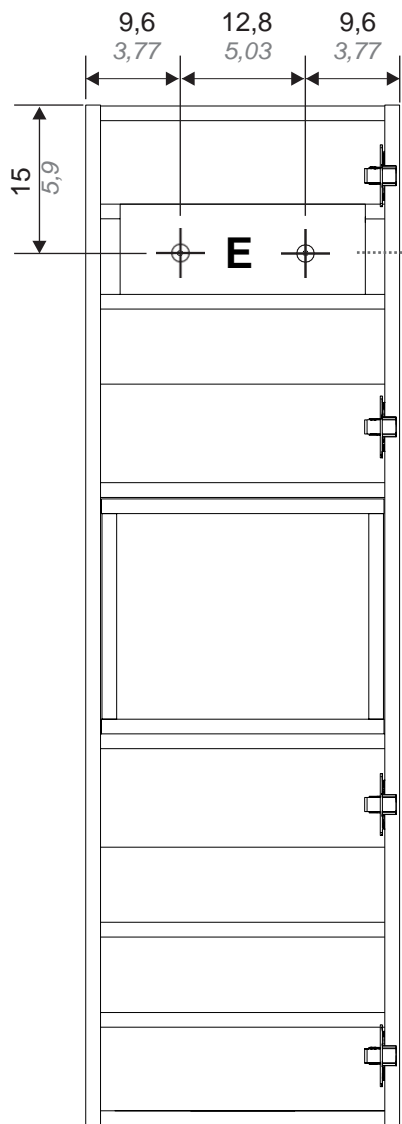

**CHAZO**  
Anchor

**PARED**  
Wall



\* Herramientas  
NO incluidas/  
Tools not  
included

Utilizar una broca  
de 5/16" para hacer  
las perforaciones  
en el muro/  
Use a 5/16" drill bit  
to drill the wall.



Tornillo 2" +  
Chazo Mariposa/  
Drywall Screw+  
Wall Anchor



**VOLTEAR/  
TURN OVER**

DEFINA EL LADO DE APERTURA  
DE LAS PUERTAS GIRANDO EL  
MUEBLE 180° / IDEFINE THE OPENING SIDE  
OF THE DOORS TURNING THE  
180 ° FURNITURE

\* Centímetros / Inches

## RECOMENDACIONES DE ENSAMBLE / ASSEMBLY RECOMENDATIONS

El buen funcionamiento del mueble depende de un adecuado ensamblaje  
An excellent furniture's performance relies on a solid and a suitable assembly.

### MINIFIX / CONNECTOR - DOWELS

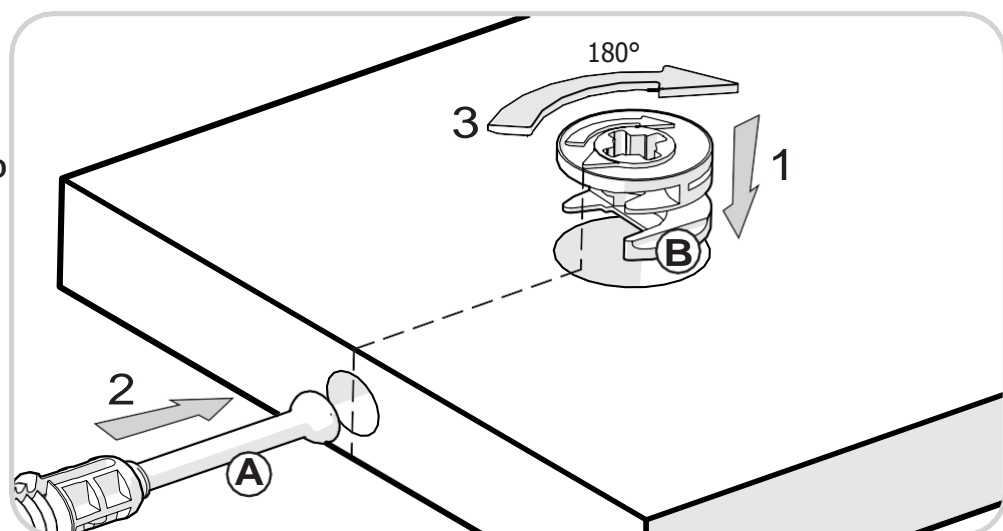

Sistema de unión compuesto por un perno (A) y una caja minifix (B).

- (1) Se inserta la caja minifix dentro de la perforación ubicada en la cara de la pieza, la flecha debe apuntar siempre a la dirección de la perforación por donde entrará el perno.
  - (2) Se debe insertar el perno por su parte plástica en las perforaciones que se indiquen, luego se inserta la punta metálica en la perforación para que su cabeza quede al interior de la caja minifix.
  - (3) Girar la caja minifix 180° para apretar las dos piezas.
- It's a fitting system made of a spreading bolt (A) and a minifix cam (B).
- (1) Insert the minifix cam in the hole placed in the face of the panel with the arrow pointing towards the hole where the bolt will fit.
  - (2) Insert the bolt with its plastic base in the shown holes, then insert the metallic bolt head in the holes so it fits inside the minifix cam.
  - (3) Tight the panels by turning the minifix cam 180°.

### TARUGOS O TAQUETES / FLUTED DOWEL PIN

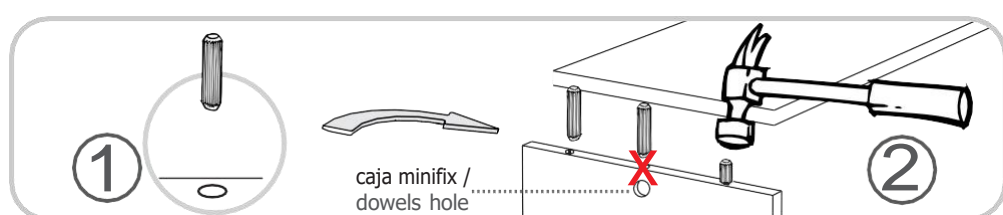

Es un pedazo de madera corto y grueso, de aproximadamente 3 a 10 cm de largo, que sirve para amarrar el mueble y darle resistencia. Tenga en cuenta que debe aplicar una gota de pegamento en cada perforación en la que se pondrá el taquete.

It's a short and thick piece of wood, 1,18 to 3,93 inches approximately, which is used to tie the cabinet and give it resistance. Take into account to apply a drop of glue on each hole you will insert the fluted dowel pin.

## RECOMENDACIONES IMPORTANTES / KEY RECOMMENDATIONS

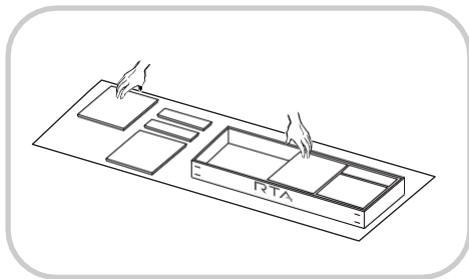

Se recomienda armar el mueble sobre la caja o una superficie lisa para no rayarlo. It is recommended to assemble the product on the box or on a flat surface to not scratch it.

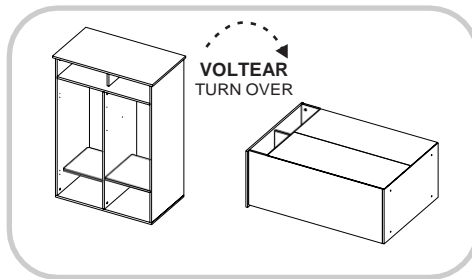

Voltear el mueble cuidadosamente para ensamblar los fondos. Carefully turn over the cabinet to assemble the back panels.

### PESO MAX. SUGERIDO EN MUEBLE (Kg) / MAX SUGGESTED LOAD (Kg)

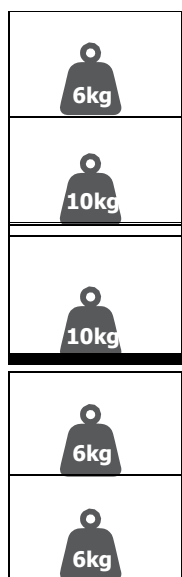

**NOTA:** La resistencia a las cargas puede variar dependiendo si es una carga distribuida o una carga puntual, las grá-cas corresponden a cargas puntuales, **NO** exceder los pesos sugeridos / **NOTE:** The load capacity depends if it is a *point load* or if it is an *uniform distributed load*, do not exceed the suggested loads.

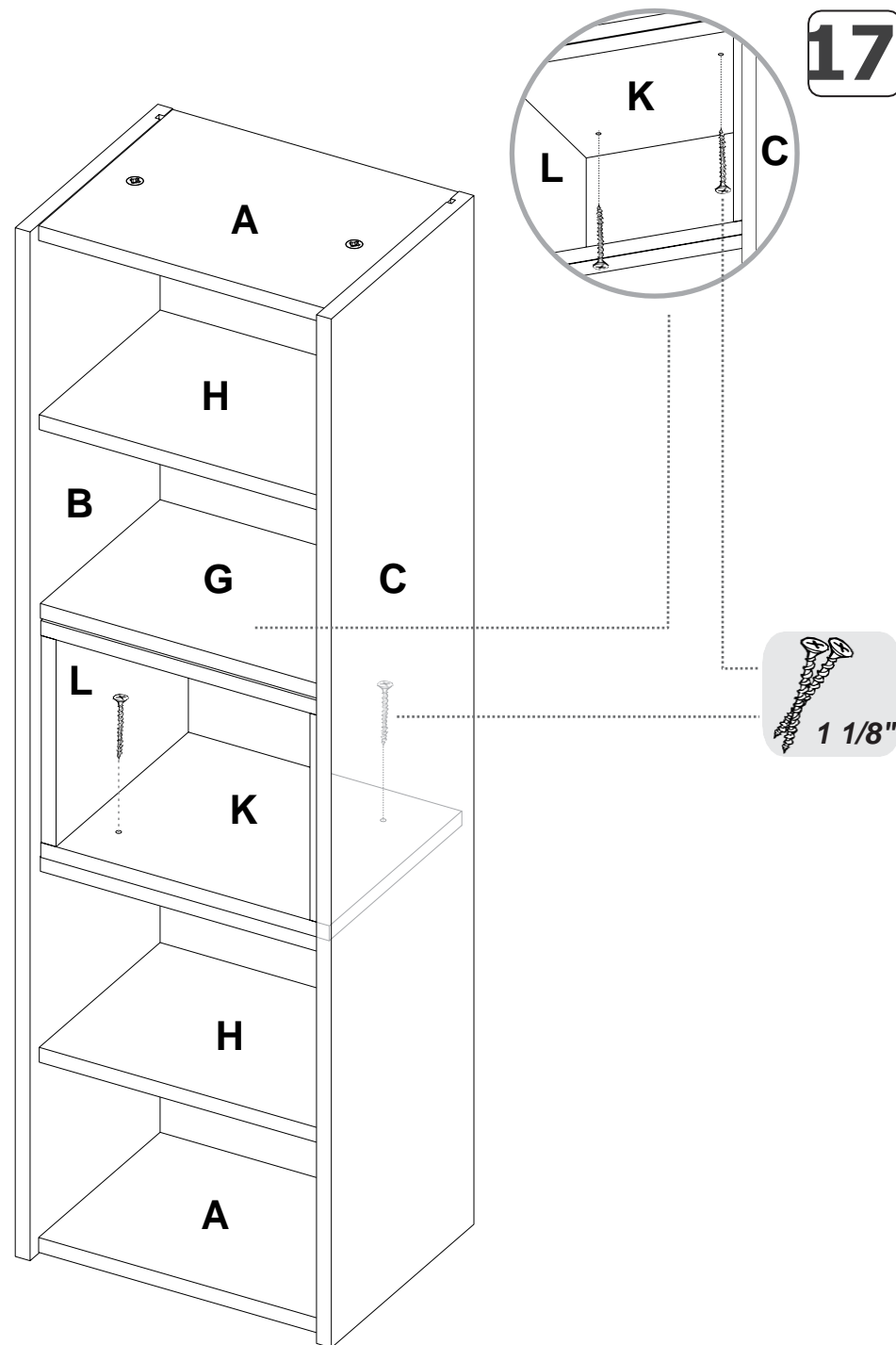

**16**

VOLTEAR EL MUEBLE CUIDADOSAMENTE / CAREFULLY FLIP THE CABINET

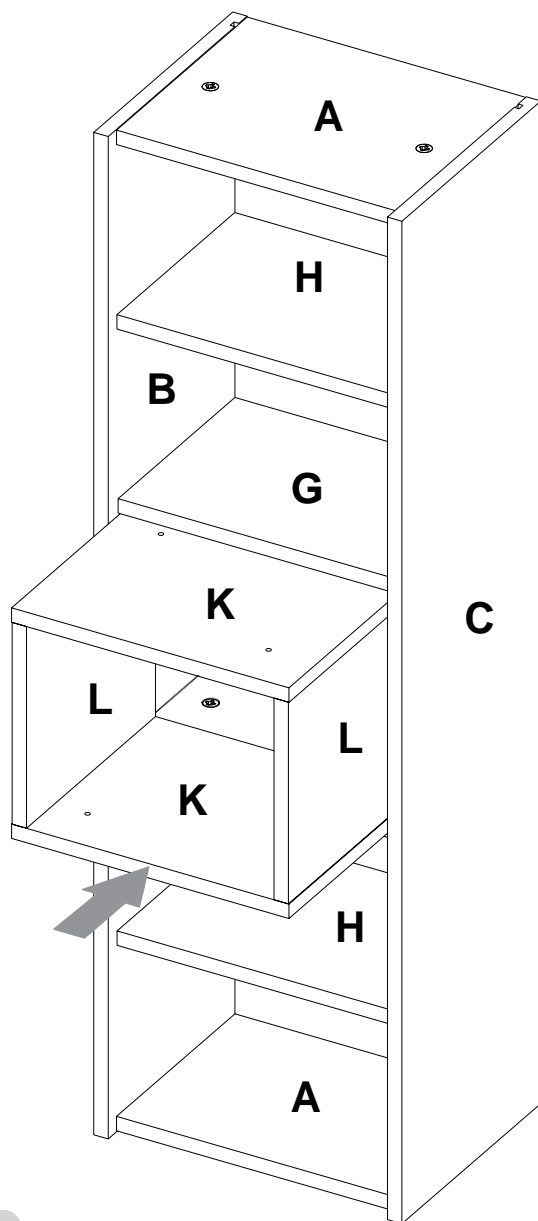

INSERTE EL MODULO  
DENTRO DEL MUEBLE / INSERT THE  
MODULE INSIDE THE CABINET

## HERRAJES PARA ARMADO ASSEMBLY HARDWARE

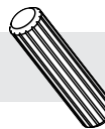
**x52**

Tarugo/  
Fluted Dowel Pin

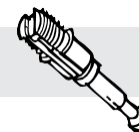
**x24**

Perno minifix/  
Spreading Bolt

**x24**

Minifix/  
Minifix Cams

**x30**

Tapa Adhesiva  
Minifix /  
Cover Caps

**x2**

Chazo Plástico +  
Tornillo de Ensamble/  
Plastic Wall Anchor +  
Drywall Screw

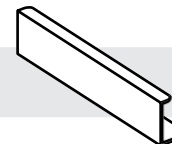
**x2**

Manija/  
Handle

**x28**

Tornillo Lámina/  
Sheet Screw

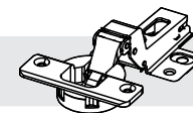
**x4**

Bisagra Interior/  
Half Overlay Hinge

**x4**

Tornillo de Ensamble 1 1/8"/  
1 1/8" Drywall Screw



TENER PRECAUCIÓN AL ABRIR LA BOLSA DE HERRAJES PARA NO EXTRAVIAR NINGUNO. COMPRUEBE QUE EL CONTENIDO DE LAS PIEZAS SEA EL CORRECTO. EN CASO QUE FALTE ALGUNA PIEZA O ESTE DEFECTUOSA DEVUELVA LAS PIEZAS AL ALMACÉN CON SU FACTURA PARA EFECTUAR EL CAMBIO DE LAS PIEZAS Y/O LOS HERRAJES LO MÁS PRONTO POSIBLE. / PLEASE BE CAUTIOUS WHEN OPENING THE HARDWARE BAG TO NOT LOSE ANY. CHECK THE CONTENTS OF THE PARTS ARE CORRECT. IF ANY PART IS MISSING OR IMPERFECT PLEASE RETURN THE PARTS TO THE STORE WITH THE PRODUCT INVOICE ATTACHED TO MAKE EFFECTIVE THE REPLACEMENT OF THE IMPERFECT PIECES OR HARDWARE AS SOON AS POSSIBLE.

# PIEZAS DE ARMADO ASSEMBLY PARTS

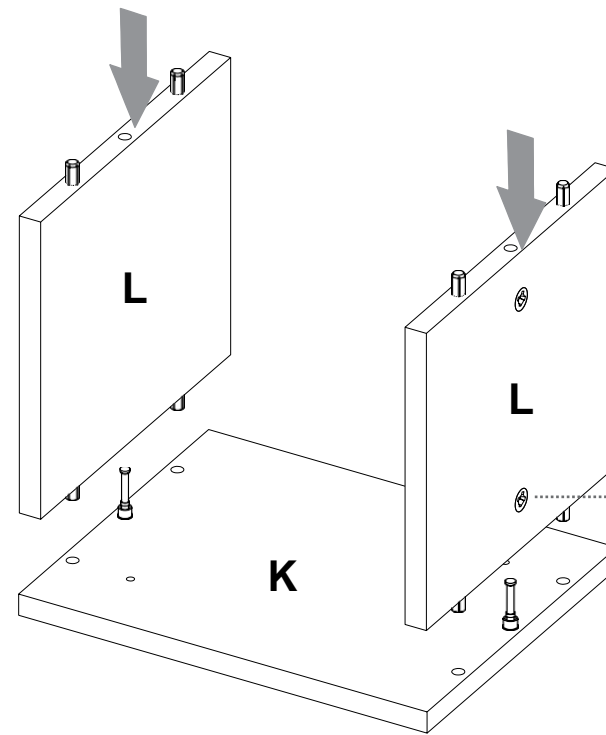
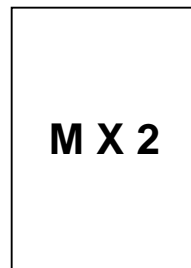
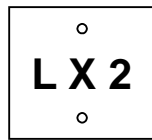
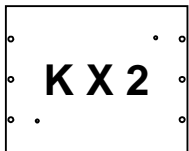
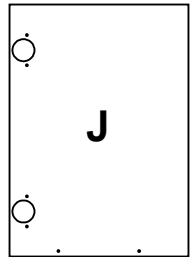
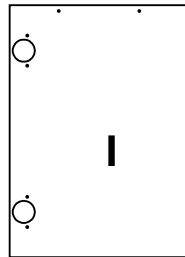
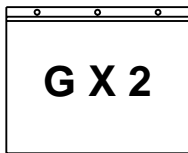
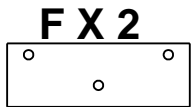
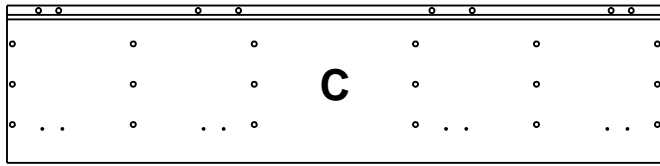
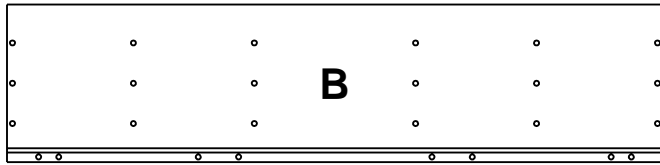
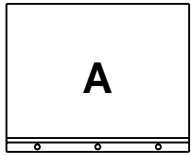

Girar 180° /  
Rotate 180°

14

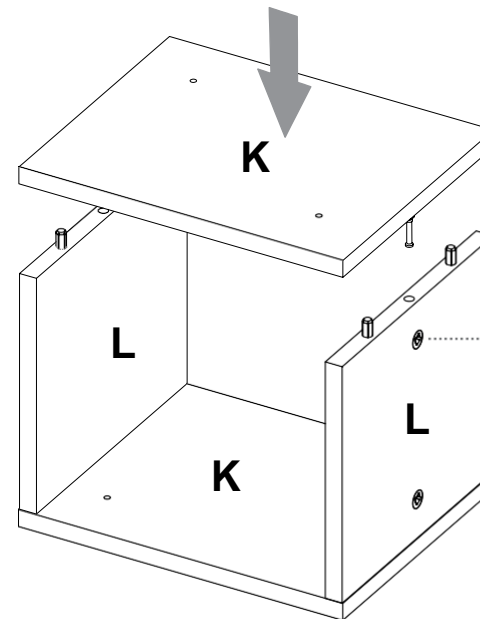

Girar 180° /  
Rotate 180°

15



ANTES DE EMPEZAR A ARMAR EL MUEBLE LEA DETENIDAMENTE LAS INSTRUCCIONES. SE RECOMIENDA ARMAR EL MUEBLE SOBRE LA CAJA O SOBRE UNA SUPERFICIE LISA Y CUBIERTA, PARA NO RAYARLO / BEFORE STARTING TO ASSEMBLE THE CABINET, CAREFULLY READ THE INSTRUCTIONS. IT IS RECOMMENDED TO ASSEMBLE THE FURNITURE ON THE BOX OR ON A FLAT AND COVERED SURFACE IN ORDER TO NOT SCRATCH THE PRODUCT.

12

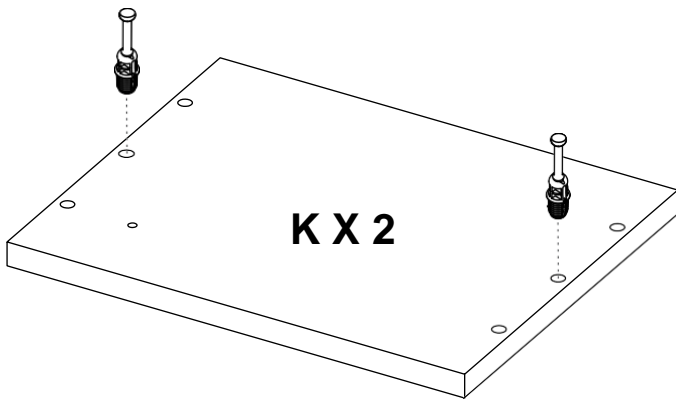

13

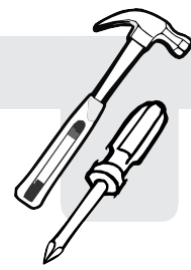
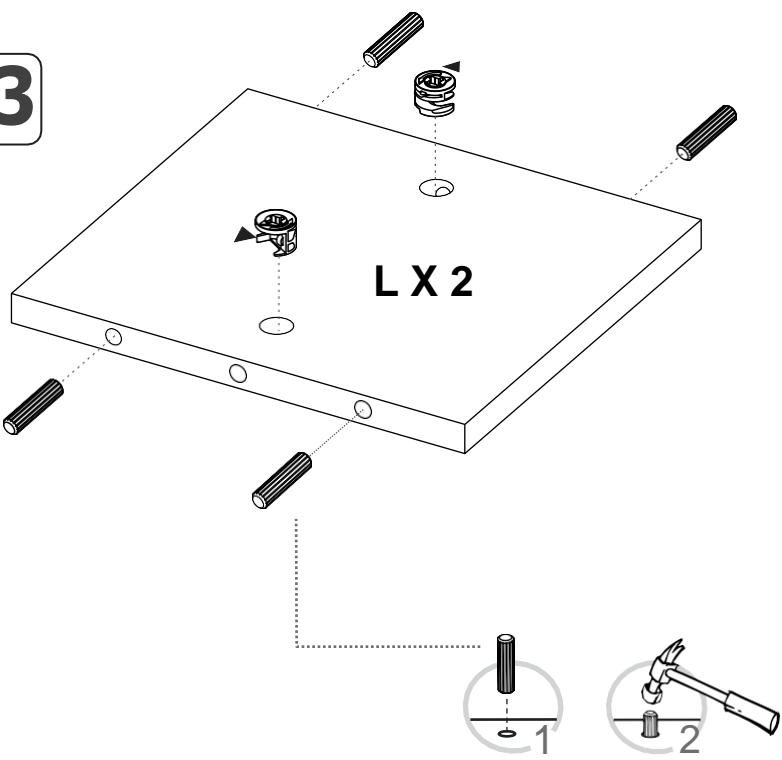

\*(Herramientas NO incluidas) \*Tools NOT Included

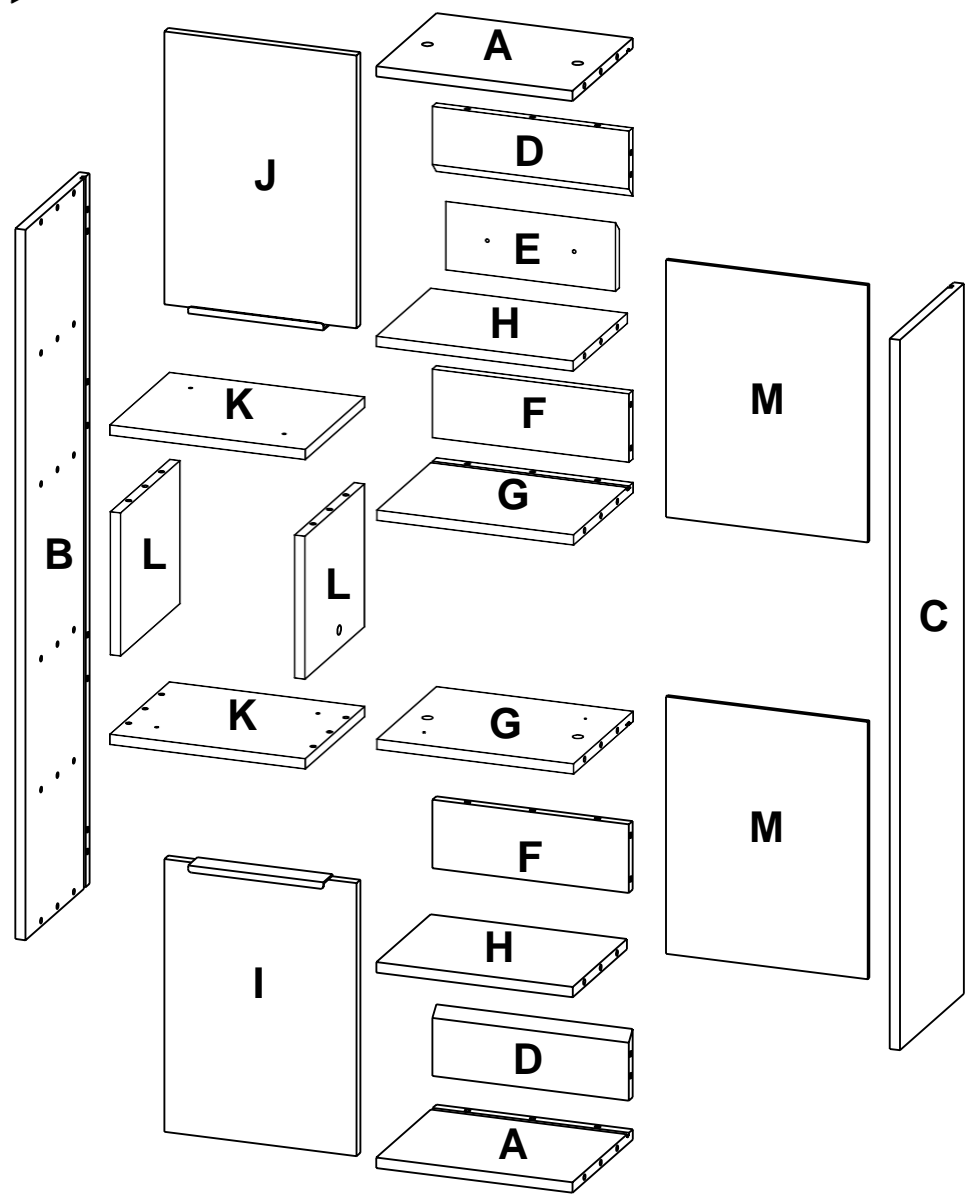

**1**

SE RECOMIENDA ARMAR EL MUEBLE ENTRE DOS PERSONAS /  
IT IS RECOMMENDED TO ASSEMBLE THE PRODUCT BETWEEN TWO PEOPLE

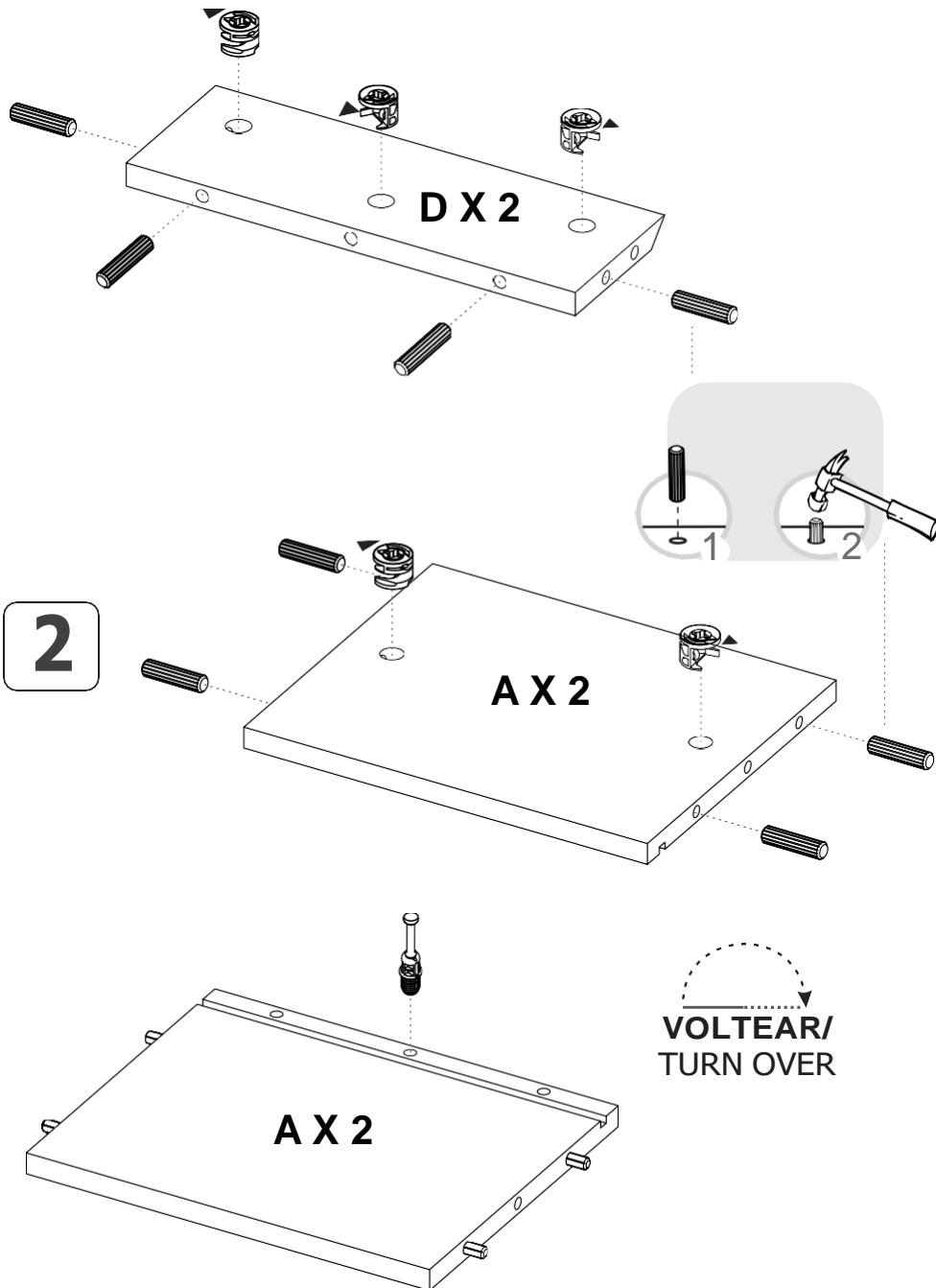
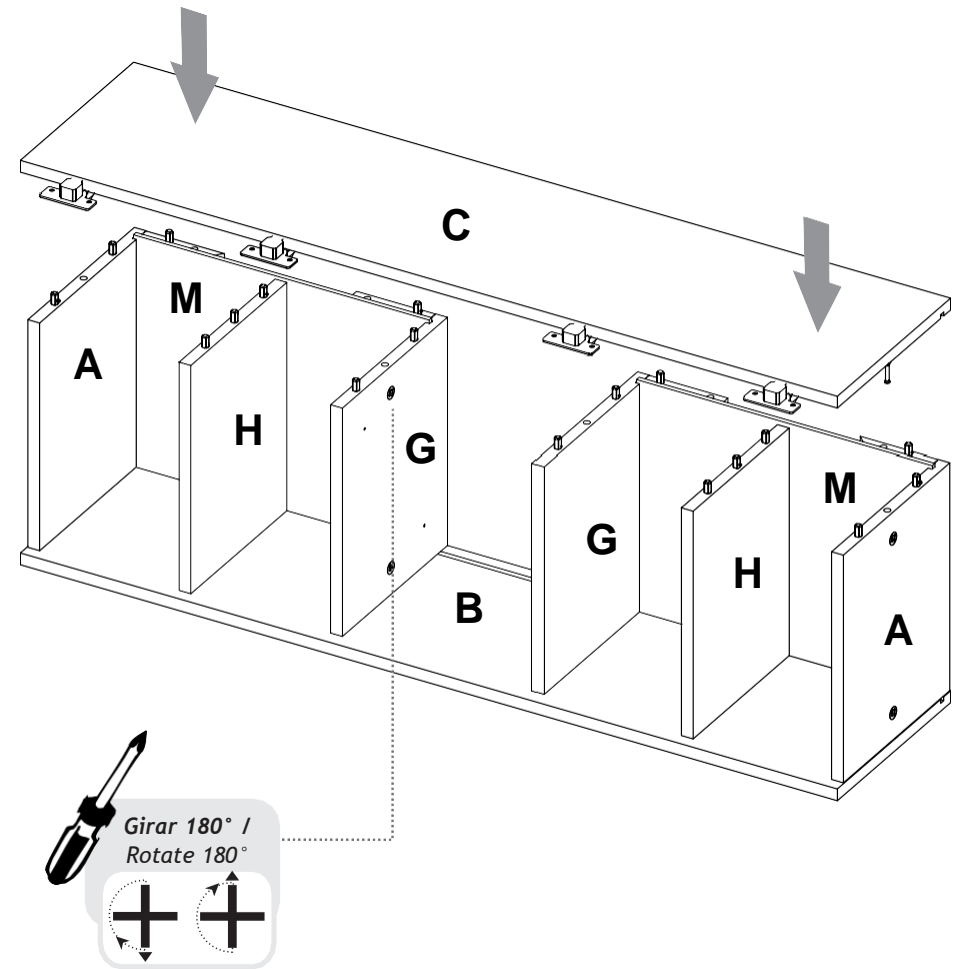
**11**

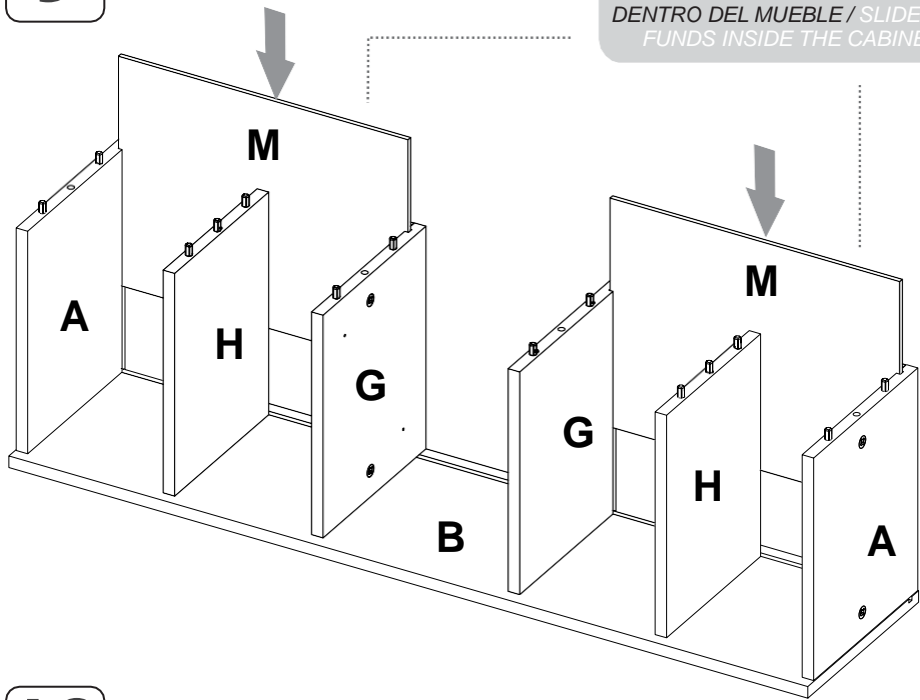
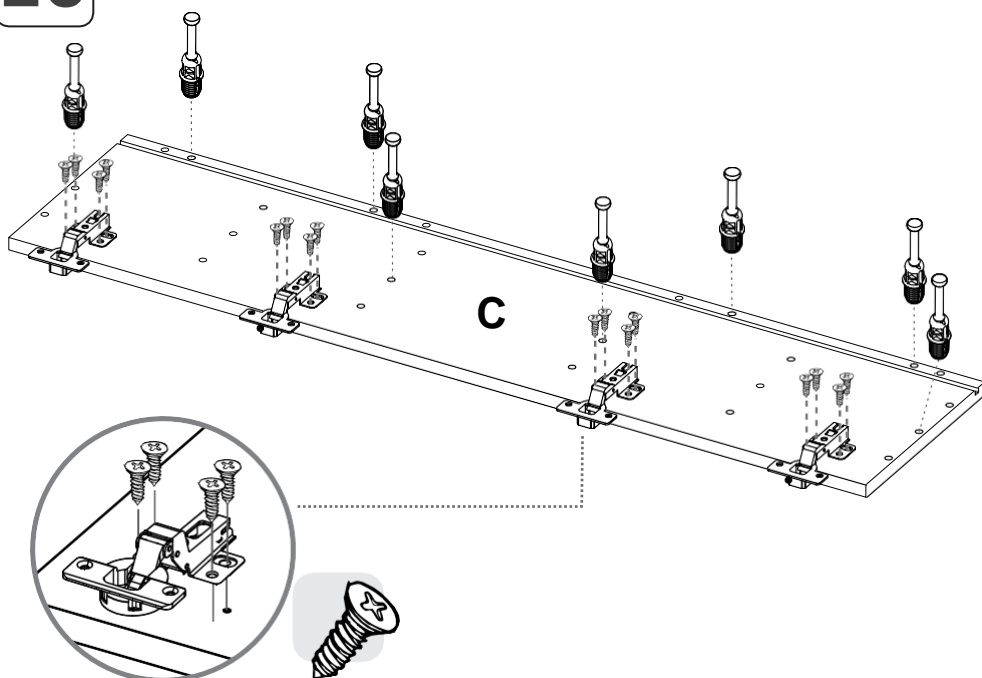
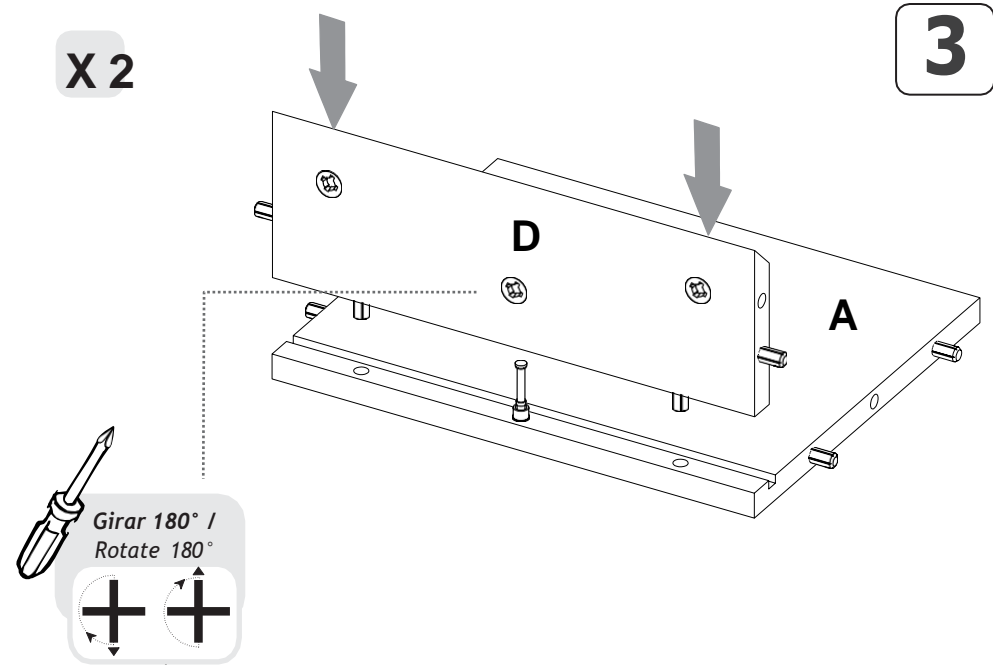
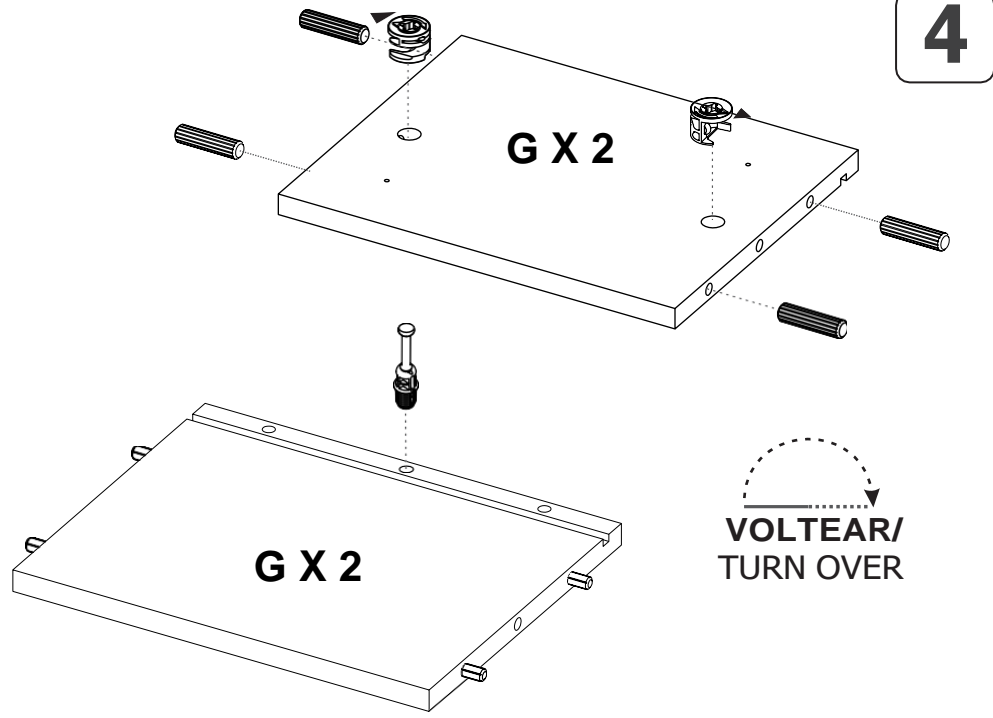

**9****10****X 2****3****4**

5

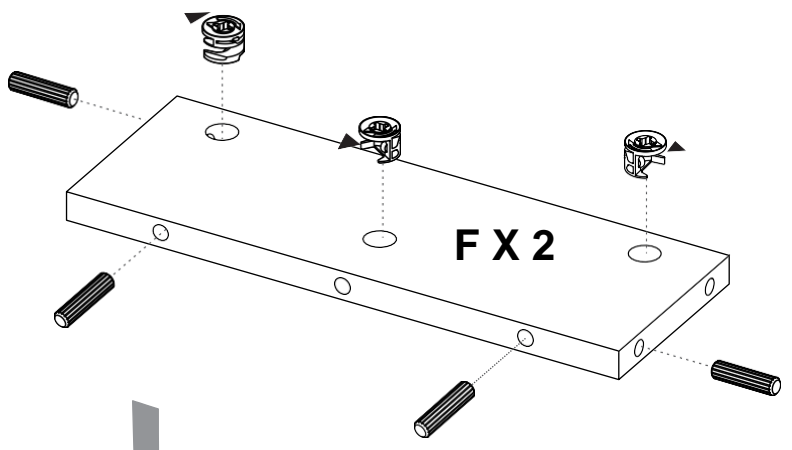

X 2

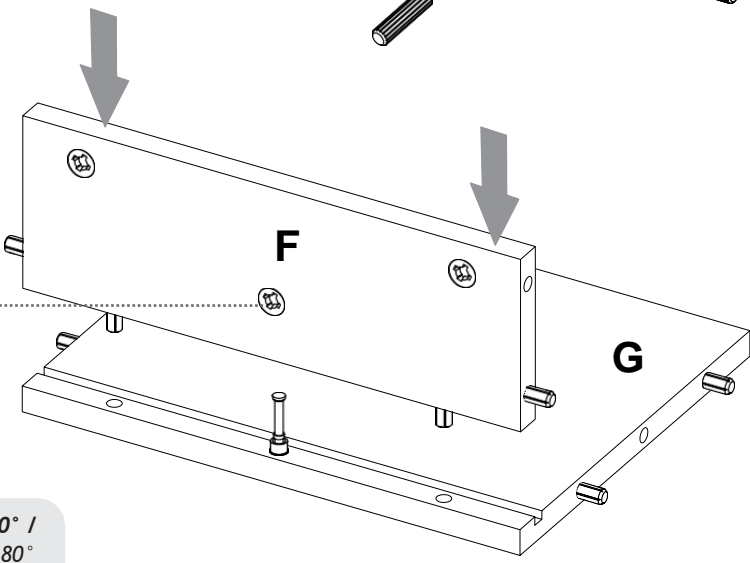

6

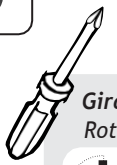

Girar 180° / Rotate 180°

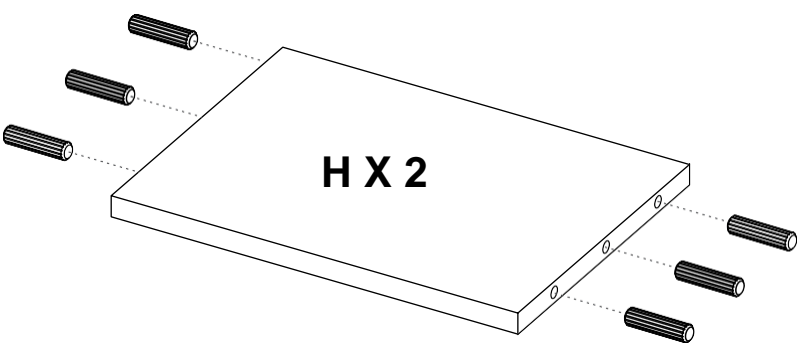
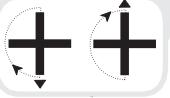

7

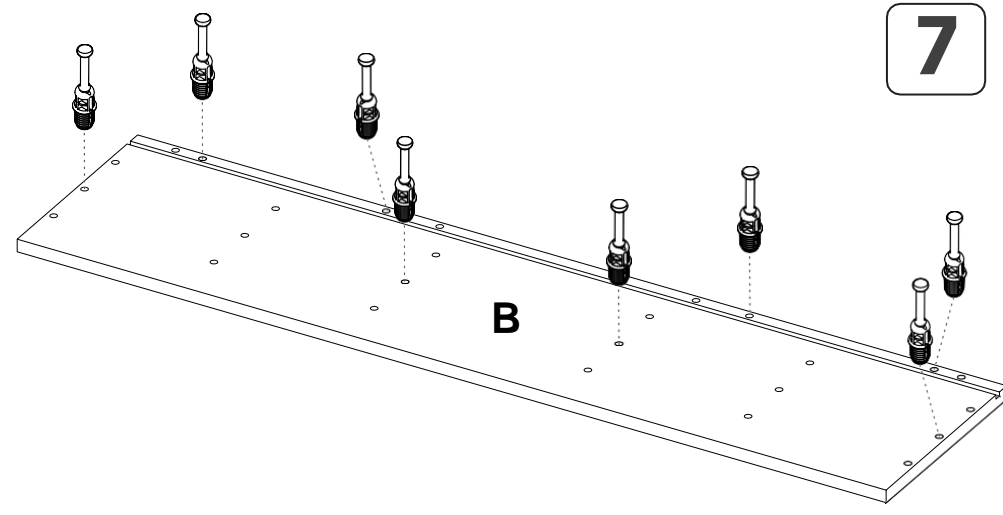

8



Girar 180° / Rotate 180°

